

# Enclosures

## Enclosures for Magno Meters & Collectors



A premium range of wall-mounted and pole-mounted plastic **enclosures**, perfectly designed for **Magno** meters and the **Magno Collector**. Built for durability and versatility, they support single-phase and three-phase supply, making them the ideal solution for residential, commercial, and industrial installations. Robust, reliable, and ready to perform—protect your meters with confidence.



UV RESISTANT



VENTILATION



EASY INSTALL



TAMPER SENSOR



# Enclosure

## Features & Functions

Supported Meter Types	Magno Meters & Magno Collector
Operating voltage range	<ul style="list-style-type: none"><li>Door opening sensing</li><li>Water drainage holes</li><li>Ventilation</li></ul>
Capacity	<ul style="list-style-type: none"><li>Size 1 Enclosure: 4 DIN Rail Meters or 1 BS Single Phase Meter or 1 DCU</li><li>Size 2 Enclosure: 1 Three Phase Meter DC or CT</li></ul>
Device Composition	<ul style="list-style-type: none"><li>Material: Polycarbonate with Glass Fibre</li><li>Common Parts:<ul style="list-style-type: none"><li>Cable Glands (PG19)</li><li>Self-Tapping screws for locking</li><li>Door Sensor (Optional)</li><li>Self-tapping screws for door sensor (Optional)</li></ul></li><li>Pole Mount:<ul style="list-style-type: none"><li>Metal Straps</li></ul></li><li>Wall Mount:<ul style="list-style-type: none"><li>Panhead screws for wall mount</li></ul></li><li>Optional Extras<ul style="list-style-type: none"><li>DIN rail bars</li><li>Circuit breakers</li><li>Cables</li></ul></li></ul>
Environmental	Suitable for Outdoor installation on pole or wall mounting
Dimensions	<ul style="list-style-type: none"><li>Size 1: 282 x 107.5 x 204 (H x W x L) mm</li><li>Size 2: 384 x 127 x 228.60 (H x W x L) mm</li></ul>

### Size 1

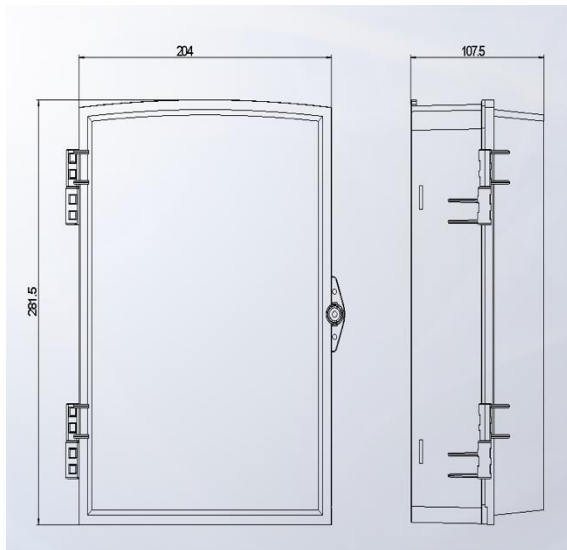

### Size 2

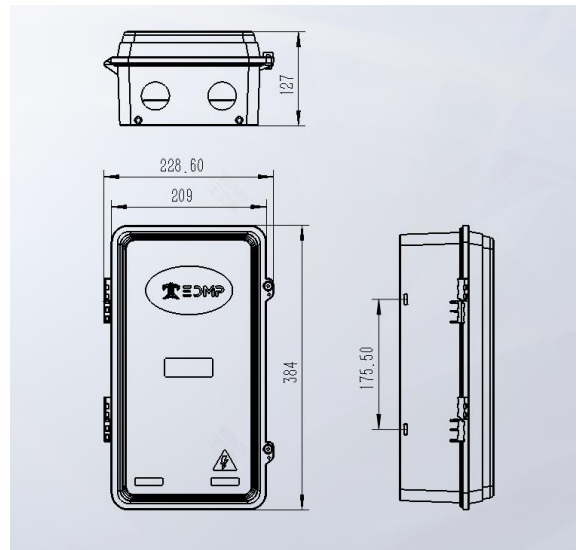

#### EDMP Trading LLC

Jumeriah Business Centre 3, Office No. 1403 & 1404,  
Cluster Y, JLT, Dubai, UAE (PO Box 118398)

info@edmpco.com

[www.edmp.tech](http://www.edmp.tech)



EDMI Gold Partner, Middle East & Africa  
Under license of EDMI Limited