

# MAGNO 33+ CT/CTVT

For Commercial and Industrial Use

Dual Source Three Phase CT/CTVT Smart Energy Meter



The **Magno 33+ CT/CTVT** is a dual source three-phase smart meter designed for commercial and industrial energy management, ideal for Advanced Metering Infrastructure (AMI) initiatives. It features **dual-source** functionality, enabling consumption measurement from multiple sources with flexible payment modes, including **dual-wallet** prepayment. Supporting both prepaid and postpaid billing options, compliant against **STS/CTS** Standard. It ensures adaptability for diverse needs. With enhanced energy measurement, power quality monitoring, load management, and automated reporting, it delivers precise, reliable data for optimized energy use and operational efficiency.



DLMS COMPLIANT



IDIS CERTIFIED



STS/CTS COMPLIANT



DUAL WALLET



# MAGNO 33+ CT/CTVT

## Main Functionalities:

Standards & Compliance	<ul style="list-style-type: none"><li>▪ IEC 62052-11, 21, 31</li><li>▪ IEC 62053-23, 24</li><li>▪ IEC 62059-31-1</li><li>▪ IEC 62059-32-1</li><li>▪ EN62053-23</li><li>▪ EN50470-3</li></ul>
Measurement	<ul style="list-style-type: none"><li>▪ 3 elements 4 quadrants</li><li>▪ Import/Export Absolute/Q1/Q2/Q3/Q4: Wh, varh and Vah</li><li>▪ Power (per phase / total): W, var, VA</li><li>▪ Vrms, Irms</li><li>▪ Power factor, frequency</li><li>▪ V-V and V-I phase angles</li><li>▪ Voltage THD, Current THD</li><li>▪ Harmonics up to 50th</li></ul>
Multi TOU Tariff	<ul style="list-style-type: none"><li>▪ Up to 8 tariff</li><li>▪ Up to 200 programmable special days Daily, Weekly, Monthly, Yearly &amp; Special</li><li>▪ Up to 32 separate import and export registers</li><li>▪ Up to 12 seasons</li><li>▪ Up to 100 Previous period plus Period totals</li></ul>
Prepayment	<ul style="list-style-type: none"><li>▪ Configurable prepayment and post-payment mode</li><li>▪ Three levels for remaining credit alarm</li><li>▪ Emergency credit, friendly time and friendly days support</li><li>▪ Dual wallet</li></ul>
Auxiliary Power	<ul style="list-style-type: none"><li>▪ 100 to 240 VAC / 140 to 340 VDC</li></ul>
Load Profile	<ul style="list-style-type: none"><li>▪ At least 50 channels</li><li>▪ Support 3 independent surveys</li><li>▪ 24hrs daily survey</li><li>▪ Intervals programmable from 1 to 60 minutes</li><li>▪ Storage 8 channels (15 min) for a year</li></ul>
Communication Ports	<ul style="list-style-type: none"><li>▪ WAN: Plug and play module to support various communication technology</li><li>▪ WAN: G3-PLC, WiSUN, LoRaWAN, Cellular (GPRS, 3G, 4G/LTE, NB-IoT), or Ethernet</li><li>▪ RF or PLC module – For communication with CIU (Customer Interface Unit)</li><li>▪ Optical: Comply with IEC 62056-21 standard, DLMS (IEC 62056-21 mode E)</li><li>▪ Additional: 2x RS485 (with Power Supply), RS232 Port, VTC interface</li></ul>
Input/Output Ports	<ul style="list-style-type: none"><li>▪ Pulse Output</li><li>▪ Dual Source Signal (Tariff change)</li><li>▪ Meter enclosure opening/tamper detection (Active input)</li><li>▪ External Relay output</li><li>▪ Pulse Input</li></ul>

# MAGNO 33+ CT/CTVT

## Additional Functionalities:

Event	<ul style="list-style-type: none"><li>▪ Fraud detection log (Meter cover &amp; terminal cover open detect with and without power, module cover open detect, current reverse, magnetic detect, neutral current mismatch etc.)</li><li>▪ Failure detection log (Memory error, relay error, battery low voltage, clock invalid etc.)</li><li>▪ Power quality event log (Under voltage / Over voltage(Sag/Swell), Over current/current imbalance, Power up/down, etc.)</li><li>▪ Security event log (Parameters change, clock adjust, etc.)</li><li>▪ Standard event log (Power up/on, time synchronization, etc.)</li></ul>
Anti Tamper	<ul style="list-style-type: none"><li>▪ More than 4 sealing positions</li><li>▪ Terminal cover, meter cover and module cover sealing</li><li>▪ Self-protection under Overload control, Abnormal voltage control, Arrearage control, Tamper control, Malfunction control, Fire disaster control etc.</li></ul>
Alarm	<ul style="list-style-type: none"><li>▪ Alarms with LED/Buzzer and LCD on CIU</li><li>▪ Alarm can be configurable</li></ul>
Tariff Expense (Optional)	<ul style="list-style-type: none"><li>▪ Up to 10 steps tariff</li><li>▪ Up to 5 steps Monthly service charge</li><li>▪ Up to 5 kinds subsidy</li><li>▪ Up to 3 kinds fixed charge</li><li>▪ Up to 5 kinds levies charge</li><li>▪ Up to 3 kinds VAT charge</li></ul>
Communication Protocol	<ul style="list-style-type: none"><li>▪ International open protocol</li><li>▪ IEC62056-21 E mode DLMS</li><li>▪ HDLC DLMS and TCPIP DLMS, Support suite 0 and suite 1</li><li>▪ STS/CTS Token and SMS</li><li>▪ LLS support 3 level passwords for local and remote communication</li><li>▪ HLS support auth and encryption for local and remote communication</li><li>▪ IDIS Compliant</li></ul>
Billing Record	<ul style="list-style-type: none"><li>▪ Up to 13-month billing data</li><li>▪ Calculate monthly net consumption of energy</li><li>▪ Up to 31 days daily data</li><li>▪ Calculate daily net consumption of energy</li></ul>
Firmware Upgrade	<ul style="list-style-type: none"><li>▪ The firmware can be upgraded via local interface and WAN interface.</li><li>▪ Schedule activity image support</li></ul>
CIU unit	<ul style="list-style-type: none"><li>▪ The meter can communicate with the CIU via RF or PLC</li><li>▪ Parameters transfer</li><li>▪ Credit token, Key change token, clear balance token, clear tamper token, set power limit token, test token etc.</li><li>▪ Fully complies with STS standard</li></ul>

# MAGNO 33+ CT/CTVT

## Technical Specification:

Rated Nominal Voltage	3x 57.7/100V~277/480V
Operating Voltage Range	80%Un~120%Un
Rated Current & Starting Current	5(20)A and 0.1% Ib
Rated Frequency	50Hz or 60Hz ±5%
Pulse Constant (Configurable)	1000imp/kWh 1000imp/kvarh (Default)
Accuracy Class	Cl.0.5s for Active kWh Cl.0.5s for Reactive kvarh
Power Consumption	Voltage circuit ≤2 W or 10VA, Current circuit ≤1 VA
Battery and Life	Replaceable Lithium battery, life more than 15 years Supercap (Optional) – 5 yr lifetime with power off
Normal Operation Range	-25°C to +60°C, Humidity is up to 95%
Limit Operation Range	-40°C to +70°C Humidity is up to 95%
EMC Performance	Impulse voltage > 6KV, AC voltage > 4KV, Short circuit current > 3KA, Electrostatic Discharge contact: 8KV & air: 15KV
Protection Class	IP54 comply with IEC60529 Insulation grade II
Housing Material	Polycarbonate with non-conductive, high impact, smooth finish, durable, non-flammable, UV stabilized, UV resistant and high resistance to weathering

## Diagram:

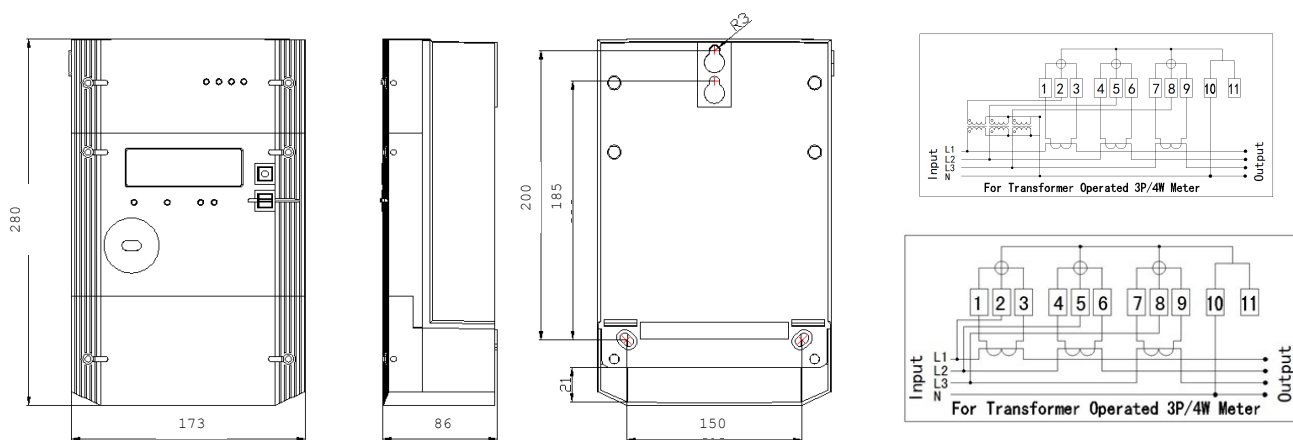

**EDMP Trading LLC**  
P3-08, 32 Marasi Drive,  
Business Bay, Dubai, UAE

info@edmpco.com  
[www.edmpco.com](http://www.edmpco.com)



EDMI Gold Partner, Middle East & Africa  
Under license of EDMI Limited