



Cellular Module



Multi Band Cellular Communication Module

Unlock seamless, high-speed connectivity with our multi-band Cellular Communication Module — the ultimate plug-in solution for global wireless communication across 5G, 4G LTE, and 2G networks. Designed to support a wide range of international frequency bands, this module ensures reliable and secure data transmission no matter where your smart metering infrastructure is deployed.

Built around a 32-bit low-power MCU based on the ARM Cortex-M0 core, the module delivers efficient and responsive performance. It integrates easily using a standard UART interface to communicate with the radio frequency system, enabling rapid deployment and compatibility with a variety of devices.

Engineered for AMI smart metering and IoT applications, this advanced module offers high data rates, intelligent wireless resource management, and robust end-to-end security. Its multi-network compatibility makes it a future-ready solution for smart grids requiring reliable connectivity, flexible integration, and truly global reach.



CELLULAR MODULE

Overview:

The EDMP Cellular Communication Module is a high-performance solution designed for smart energy metering applications, offering ultra-reliable, low-latency connectivity with wide-area coverage. As part of the international 5G standard, it ensures enhanced data throughput, secure communication, and massive device connectivity — all while maintaining energy efficiency and scalability.

This advanced module supports EDMP's Magno and Mega series smart meters, enabling real-time data acquisition, remote monitoring, event reporting, and two-way control. It ensures seamless integration with the GridLynk Head End System (HES), allowing comprehensive AMI functionality including big data analytics, demand forecasting, and grid optimization.

The module features automatic fallback to 4G LTE and 2G networks, ensuring continuous operation in areas with limited 5G coverage. It connects via a dedicated local interface on the meter and includes power-down event (Last Gasp) reporting, enabling the system to monitor and react to grid conditions and network status in real time.

Features:

Supported Network & Bands	The communication module is designed based on an international mainstream industrial NB-IoT chip, supporting multi-band B3/B5/B8/B20/B28, has the characteristics of low power consumption, high sensitivity, etc., and can also support 2G mode.
Firmware	Supports over the air upgrade Update via USB Port
Protocol	Supports TCP/FTP/DNS protocol
Configuration	Remote SMS Configuration Control via AT Commands
Data Transfer	<ul style="list-style-type: none">• FDD LTE: Max. 10Mbps(DL), Max.5Mbps(UL)• TDD LTE: Max. 8.95Mbps(DL), Max.8.1Mbps(UL)• GPRS: Max. 85.6Kbps(DL), Max. 85.6Kbps(UL)
Certification	CE for international compliance
Extended Signal	The communication module supports short antennas or external long antennas to be suitable for occasions with different signal strengths.
Installation	Pluggable standard modules, supporting interconnection of multi-manufacturer standard modules

CELLULAR MODULE

Main Specification:

Operating Temperature	-25 ° C to +75 ° C
Storage and transportation temperature	-25° C to +85 ° C
Average lifetime	15 years
Reference standards	<ul style="list-style-type: none">EN301908-1/13, EN301489-1/52, EN50385, EN62368-1; CE/RED certificate, 3GPP Release 13.0 & 14.0
Installation Method	<ul style="list-style-type: none">Hot pluggable Standard Module
Protocol stack	<ul style="list-style-type: none">TCP & UDP (Ping and Traceroute supported)DLMS/COSEM
SIM card	<ul style="list-style-type: none">Support 2FF size SIM cardSupport IPv4/IPv6, AT Commands
Antenna	<ul style="list-style-type: none">External / Internal Both.
Supported frequency band	<ul style="list-style-type: none">NB:B3/B5/B8/B20/B28GSM:850/900/1800/1900MHz
Maximum output power	<ul style="list-style-type: none">NB:Class5(21dBm+1.7/-3dB)GSM850:Class4(33dBm±2dB)GSM900:Class4(33dBm±2dB)DCS1800:Class1(30dBm±2dB)PCS1900:Class1(30dBm±2dB)
Communication sensitivity	<ul style="list-style-type: none">-123dBm @ 15KHz
Operating Voltage	<ul style="list-style-type: none">12VDC
Power Consumption	<ul style="list-style-type: none">Standby: < 2mA (@ DRX = 1.28 s)eDR: < 1 mA (@ eDRX = 40.96 s, PTW = 10.24 s)PSM: < 4.5 uA
Link Mode	<ul style="list-style-type: none">250mA @ Radio Transmission, 23dBm (B1/B3)220mA @ Radio Transmission, 23dBm (B8/B5/B20)280mA @ Radio Transmission, 23dBm (B28)130mA @ Radio Transmission, 12dBm (B3/B8/B5/B20/B28)70mA @ Radio Transmission, 0dBm (B3/B8/B5/B20/B28)60mA @ Radio Reception
Data Transmission Rate	<ul style="list-style-type: none">Data rate Cat NB1: 32 Kbps/72 Kbps (DL/UL)Cat NB2: 125 Kbps/150 Kbps (DL/UL)GPRS: 85.6 Kbps (DL/UL)
Super capacitor	<ul style="list-style-type: none">With super capacitor, support power outage active reporting function
Communications	<ul style="list-style-type: none">Supports bidirectional communication, full duplex
Electrostatic protection	<ul style="list-style-type: none">IEC61000-4-2Contact discharge: ± 8 kVAir discharge: ± 15 kV
RF Immunity	<ul style="list-style-type: none">IEC61000-4-3Frequency range: 80-1,000 MHz Electric field strength: 30V/mModulation: 80%, AM, 1kHz sine wave (with idle mode; non-transmit and non-receive)According to CISPR 22 (idle mode-not transmit & not receive)
Reliability	<ul style="list-style-type: none">IEC 61709-2017 Reliability of Electronic Components15 years
GPRS / NB-IoT Selection mechanism	Automatic detection and switching
Vibration test	<ul style="list-style-type: none">IEC-62052-11,IEC 60068-2-6IEC 60068-2-27
Certification Requirements	<ul style="list-style-type: none">CE, SGS certificates for all frequency bands supported.CITC KSA compliant

CELLULAR MODULE

LED Indicators:

LED	Colour	Description
Power	Red	Red LED on, indicates power is normal
Net	Green	Green Led flashes, indicate module is connecting to the network
RXD	Red	Red LED flashes, Receive data from cellular station
TXD	Green	Green LED flashes, Sent data to cellular station

UART Interface:

Pin #	Signal Name	Pin Type	Description
1, 2	DC_12V	Power Supply	2 parallel pins connected are capable to supply 12V DC \pm 0.2V , regulated @600mA output for long term; @1A output for peak value.
3, 4	GND		
5	TXD		Serial Data from MCU to Meter
6	NC		
7	NC		
8	RXD		Serial Data from MCU to Meter
9	Reset Module / Last Gasp	Signal (meter output) 3.3V TTL/CMOS	Reset the communication module or Last gasp notification to module
10	NC		
11	NC		
12	NC		

Dimensions:

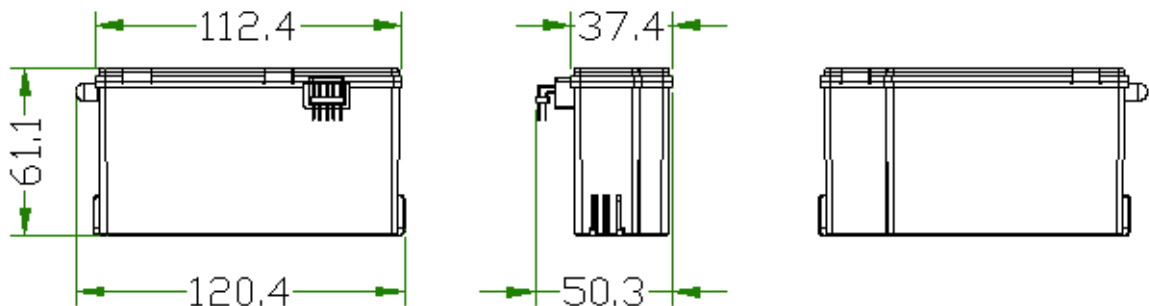

EDMP

PO Box 125428, Plot No. MO0147C, Junction of N400 & N406 Streets,
Jebel Ali Free Zone, Dubai, United Arab Emirates
info@edmpco.com www.edmpco.com

Copyright © 2026 EDMP Limited. All Rights Reserved. All trademarks are the property of their respective holders. EDMP's Policy is one of continuous product development and the right is reserved to modify specifications contained herein without notice.