

# MAGNO 33

For Residential and Commercial Use



Powering the Future with  
Precision and Control

The **Magno 33** is a directly connected **three-phase** smart meter designed for commercial and industrial energy management, supporting Advanced Metering Infrastructure (AMI) initiatives.

Equipped with advanced anti-tamper features, the Magno 33 helps utilities safeguard their revenues by detecting fraud and minimizing line losses. This high-performance meter is fully compliant with **STS/CTS standards** for prepaid metering and the **DLMS/COSEM protocol**, ensuring seamless compatibility with a wide range of systems.

With its reliable, robust performance, the **Magno 33** is the ideal solution for both residential and commercial customers, delivering exceptional accuracy, security, and efficiency in energy management.



ELECTRICITY



G3-Alliance

THREE PHASE DIRECT CURRENT  
SMART ENERGY METER

# Main Functionalities

## Standards & Compliance

- IEC 31 ,21 ,11-62052
- IEC 24 ,23-62053
- IEC 1-31-62059
- IEC 1-32-62059
- EN23-62053
- EN3-50470

## Measurement

- 3 elements 4 quadrants
- Import/Export Absolute/Q1/Q2/Q3/Q4: Wh, varh and VAh
- Power (per phase / total): W, var, VA
- Vrms, Irms
- Power factor, frequency
- V-V and V-I phase angles
- Voltage THD, Current THD
- Harmonics up to 50th

## Multi TOU Tariff

- Up to 8 tariff
- Up to 200 programmable special days Daily, Weekly, Monthly, Yearly & Special
- Up to 32 separate import and export registers
- Up to 12 seasons
- Up to 100 Previous period plus Period totals

## Prepayment

- Configurable prepayment and post-payment mode
- Three levels for remaining credit alarm
- Emergency credit, friendly time and friendly days support
- Dual wallet
- Meter Keypad (Optional)

## Load control

- Remote control command support
- Over current control support
- Power limit support
- 3 poles internal relay
- Re-connect/Dis-connect by locally or remotely

## Load Profile

- At least 50 channels
- Support 3 independent surveys
- 24hrs daily survey
- Intervals programmable from 1 to 60 minutes
- Storage 8 channels (15 min) for a year

## Communication Ports

- WAN: Plug and play module to support various communication technology
- WAN: G3-PLC, WiSUN, Cellular (GPRS, 3G, 4G/LTE, NB-IoT), or Ethernet
- RF or PLC module – For communication with CIU (Customer Interface Unit)
- Optical: Comply with IEC 62056-21 standard, DLMS(IEC 62056-21 mode E)
- Additional: RS485 (2 wire), VTC interface

## Input/Output Ports (Optional)

- Pulse Output
- Dual Source Signal (Tariff change)
- Meter enclosure opening/tamper detection (Active input)
- External Relay output

## Additional Functionalities:

<b>Event</b>	<ul style="list-style-type: none"><li>● Fraud detection log (Meter cover &amp; terminal cover open detect with and without power, module cover open detect, current reverse, magnetic detect, neutral current mismatch etc.)</li><li>● Failure detection log (Memory error, relay error, battery low voltage, clock invalid etc.)</li><li>● Power quality event log (Under voltage / Over voltage(Sag/Swell) ,Over current/current imbalance, Power up/down, etc.)</li><li>● Security event log (Parameters change, clock adjust, etc.)</li><li>● Standard event log (Power up/on, time synchronization, etc.)</li></ul>
<b>Anti Tamper</b>	<ul style="list-style-type: none"><li>● More than 4 sealing positions</li><li>● Terminal cover, meter cover and module cover sealing</li><li>● Self-protection under Overload control, Abnormal voltage control, Arrearage control, Tamper control, Malfunction control, Fire disaster control etc.</li></ul>
<b>Alarm</b>	<ul style="list-style-type: none"><li>● Alarms with LED/Buzzer and LCD on CIU</li><li>● Alarm can be configurable</li></ul>
<b>Tariff Expense (Optional)</b>	<ul style="list-style-type: none"><li>● Up to 10 steps tariff</li><li>● Up to 5 steps Monthly service charge</li><li>● Up to 5 kinds subsidy</li><li>● Up to 3 kinds fixed charge</li><li>● Up to 5 kinds levies charge</li><li>● Up to 3 kinds VAT charge</li></ul>
<b>Communication Protocol</b>	<ul style="list-style-type: none"><li>● International open protocol</li><li>● IEC62056-21 E mode DLMS</li><li>● HDLC DLMS and TCP/IP DLMS, Support suite 0 and suite 1</li><li>● STS/CTS Token and SMS</li><li>● LLS support 3 level passwords for local and remote communication</li><li>● HLS support auth and encryption for local and remote communication</li></ul>
<b>Billing Record</b>	<ul style="list-style-type: none"><li>● Up to 13-month billing data</li><li>● Calculate monthly net consumption of energy</li><li>● Up to 31 days daily data</li><li>● Calculate daily net consumption of energy</li></ul>
<b>Firmware Upgrade</b>	<ul style="list-style-type: none"><li>● The firmware can be upgraded via local interface and WAN interface.</li><li>● Schedule activity image support</li></ul>
<b>CIU unit</b>	<ul style="list-style-type: none"><li>● The meter can communicate with the CIU via RF or PLC</li><li>● Parameters transfer</li><li>● Credit token, Key change token, clear balance token, clear tamper token, set power limit token, test token etc.</li><li>● Fully complies with STS standard</li></ul>

# Technical Specification:

<b>Rated Nominal Voltage</b>	3x 208/120V~480/277V
<b>Operating Voltage Range</b>	80%Un~120%Un
<b>Rated Current &amp; Starting Current</b>	(100)5A and 0.4 % Ib
<b>Rated Frequency</b>	50Hz or 60Hz ±5%
<b>Pulse Constant (Configurable)</b>	1000imp/kWh 1000imp/kvarh (Default)
<b>Accuracy Class</b>	Cl.1 for Active Cl.2 for Reactive
<b>Power Consumption</b>	Voltage circuit ≤2 W or 5VA, Current circuit ≤0.5 VA
<b>Battery and Life</b>	Replaceable Lithium battery, life more than 15 years Supercap (Optional) – 5 yr lifetime with power off
<b>Normal Operation Range</b>	-25°C to + 60°C, Humidity is up to 95%
<b>Limit Operation Range</b>	-40°C to + 70°C, Humidity is up to 95 %
<b>EMC Performance</b>	Impulse voltage > 6KV, AC voltage > 4KV, Short circuit current > 3KA, Electrostatic Discharge contact: 8KV & air: 15KV
<b>Protection Class</b>	IP54 compliant with IEC 60529 Insulation grade II
<b>Housing Material</b>	Polycarbonate with non-conductive, high impact, smooth finish, durable, non-flammable, UV stabilized, UV resistant and high resistance to weathering

## Diagram

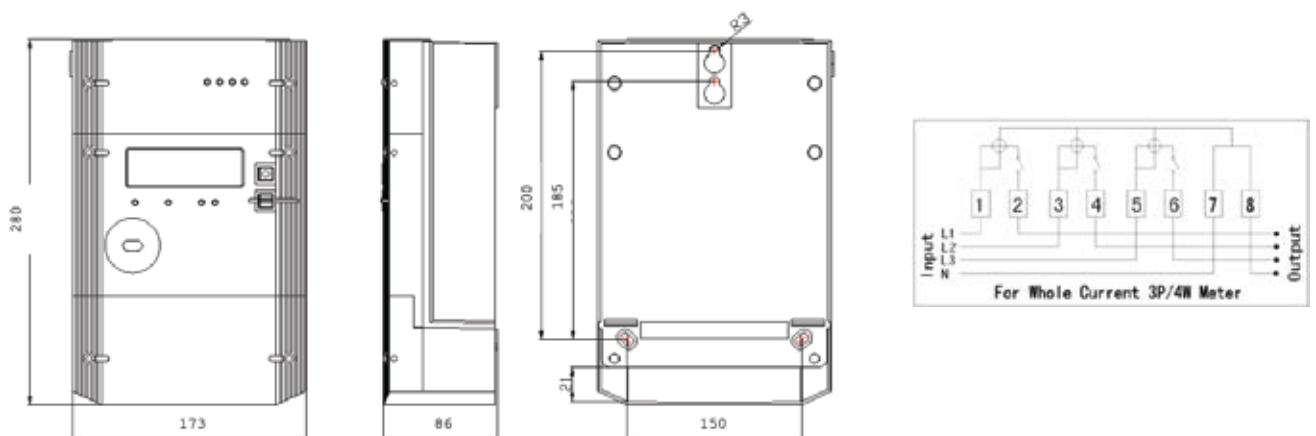

EDMP

PO Box 125428, Plot No. MO0147C, Junction of N400 & N406 Streets,  
Jebel Ali Free Zone, Dubai, United Arab Emirates

info@edmpco.com www.edmpco.com

Copyright © 2026 EDMP Limited. All Rights Reserved. All trademarks are the property of their respective holders. EDMP's Policy is one of continuous product development and the right is reserved to modify specifications contained herein without notice.